

Endurance
wind power

GREEN ENERGY THAT WORKS

E-3120
50 kW model

- 1 Anemometer & wind vane
- 2 Lightning protection
- 3 Control panel
- 4 Induction generator
- 5 Fail-safe disk braking system
- 6 Main shaft with two bearings
- 7 Gearbox
- 8 Access ladder
- 9 Yaw damper
- 10 Pitch control safety system (patent pending)
- 11 Fiberglass blade

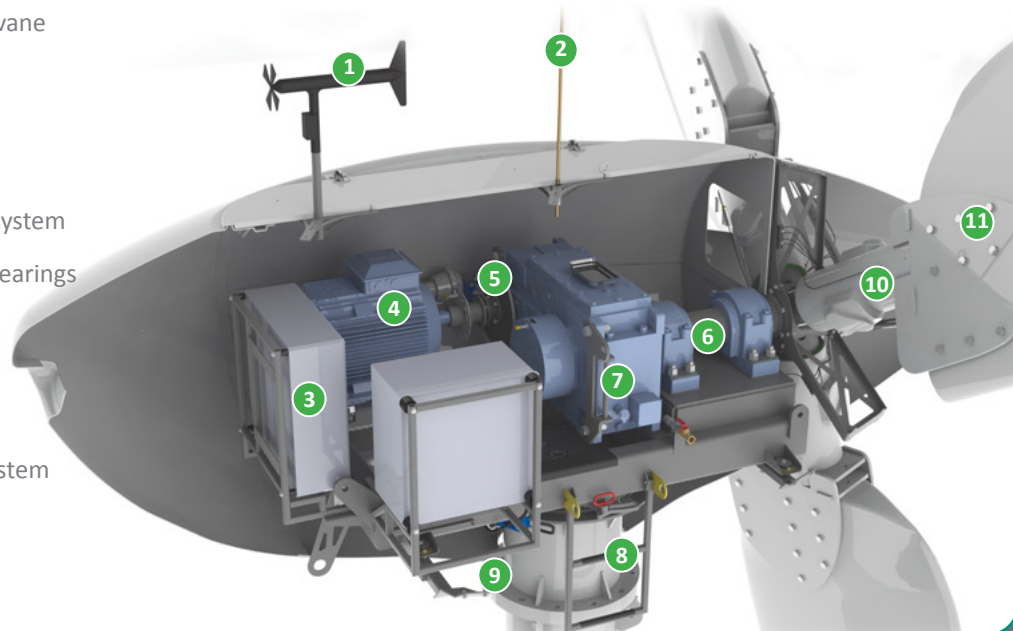

endurancewindpower.com

SPECIFICATIONS

E-3120

TURBINE

Configuration	3 blades, horizontal axis, downwind
Rated power @ 11 m/s	55 kW
Applications	Direct grid-tie
Rotor speed	43 rpm
Cut-in wind speed	3.5 m/s (7.8 mph)
Cut-out wind speed	25 m/s (56 mph)
Survival wind speed	52 m/s (116 mph)
Design lifetime	30 years *
Overall weight	3990 kg (8800 lbs)

ROTOR

Rotor diameter	19.2 m (63.0 ft)
Swept area	290 m ² (3120 ft ²)
Blade length	9.00 m (29.5 ft)
Blade material	Fiberglass / Epoxy
Power regulation	Stall control (constant speed)

GENERATOR

Type	Induction generator
Configurations	3φ, 400 VAC @ 50 Hz

BRAKE & SAFETY SYSTEMS

Main brake system	Rapid fail-safe dual mechanical brakes
Secondary safety	Pitch control system (for over-speed regulation) using passive spring-loaded mechanism (patent pending)
Automatic shut down triggered by :	<ul style="list-style-type: none"> - High wind speed - Grid failure - Over-speed - All other fault conditions

CONTROLS

Control System	Programmable logic controller (PLC)
User interface	Wireless or wired networked software interface for remote monitoring and control

WARRANTY

Turbine & controls	5 years
--------------------	---------

TOWERS

Types	Free-standing monopole: 25 m hub height
Maintenance access	Safe climbing system Working space inside the nacelle Tower-top work platform

*Provided service and maintenance schedules are strictly followed



POWER CURVE

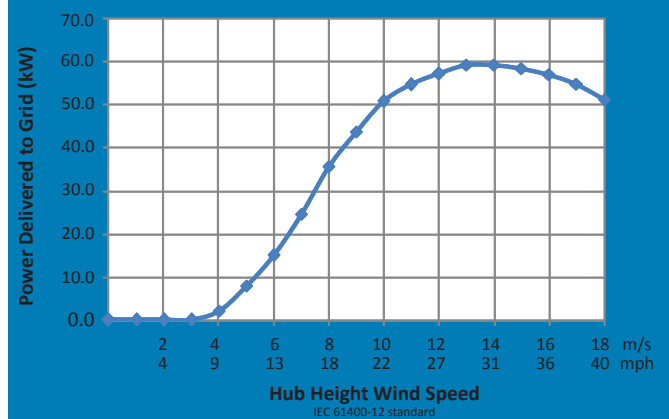

ANNUAL ENERGY PRODUCTION (AEP)

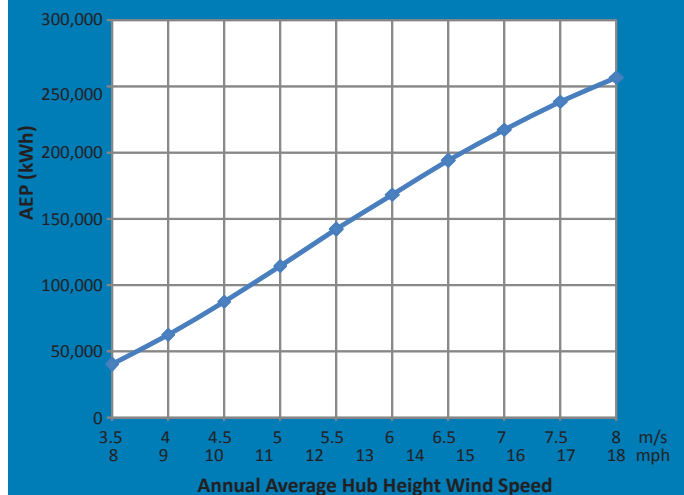

Your local Endurance dealer:



Lowestoft Office
Tel: 01502 515 532
Ringwood Office
Tel: 01202 828294

www.solarenergyalliance.com

Endurance



SO GREEN! We print our brochures on recycled paper and use only all-natural soy-based ink, rather than nasty petroleum-based products. Even the protective aqueous coating is environmentally friendly, water-based and biodegradable!

April 2010 © Endurance Wind Power

